

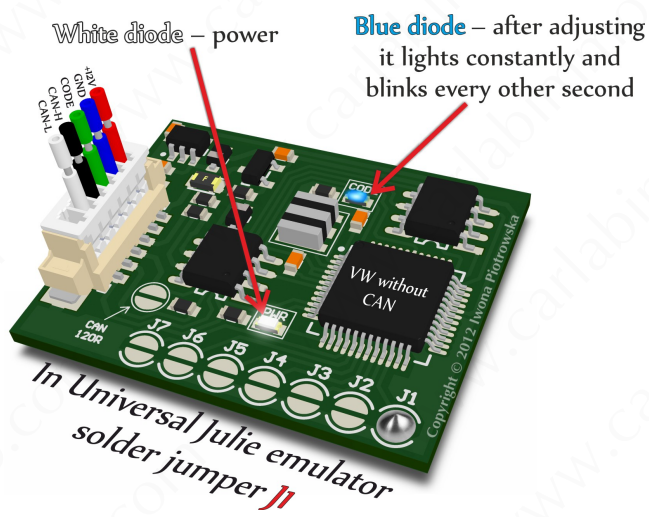

VW without CAN IMMO EMULATOR



Use

W1 and W2 systems up to around 2001

EDC15 and 5-socket LT28/LT35 ECUs - when the chassis numbers are not entered - even up to 2006

Diesel and petrol Ford cars with VW systems (the VW symbol is visible on the ECU)

Connecting in place of the original immobiliser or instrument cluster

GND

blue

+12V ACC

red

line W

green

If you cannot start the car, you need to fit the emulator to ECU

If the emulator is not working, then connect the power supply of the emulator to +12V through the reset button

Disconnect immo and connect W line with K line to have a diagnosis.

Cars with immobiliser integrated in instrument cluster

cars as of 1998

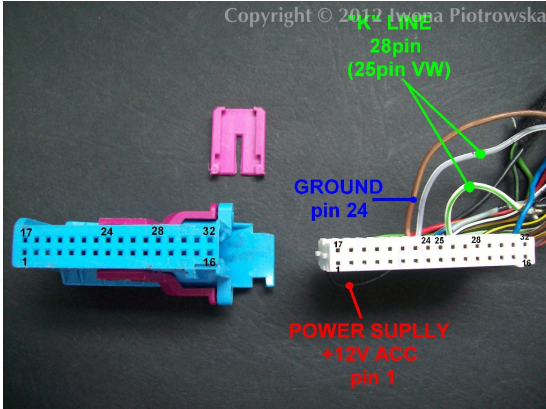

GND - pin 24 blue plug

+12V ACC - pin 1 blue plug

K-line - blue plug: pin 25 VW or pin 28 Audi

W-line - green plug: pin 5

**Cut K-line and W-line off
the instrument cluster!!!**

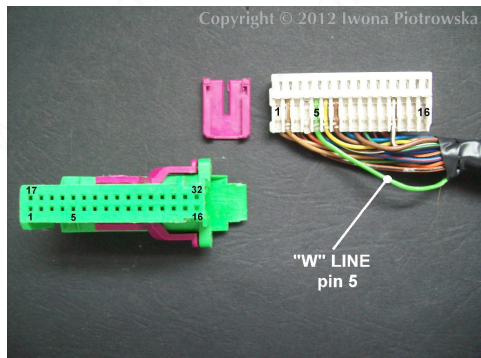

Cars with separate immobiliser

a) 6-pin immobiliser plug

GND	pin 4 and 6
+12V ACC	pin 1
K line	pin 3
W line	pin 2

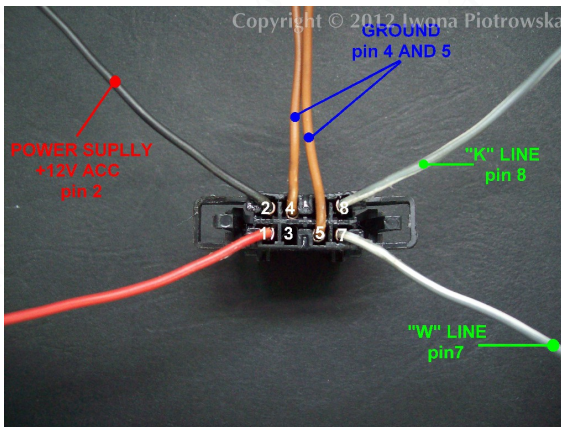
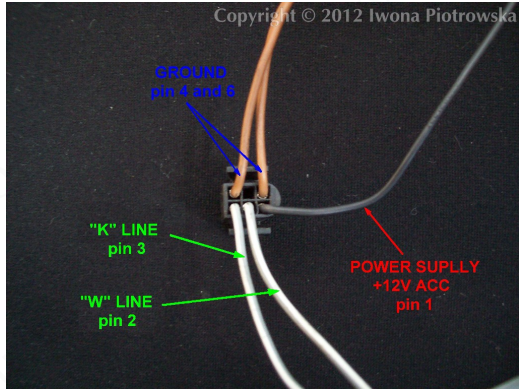

b) 8-pin immobiliser plug

GND	pin 5 and 4
+12V ACC	pin 2
K line	pin 8
W line	pin 7

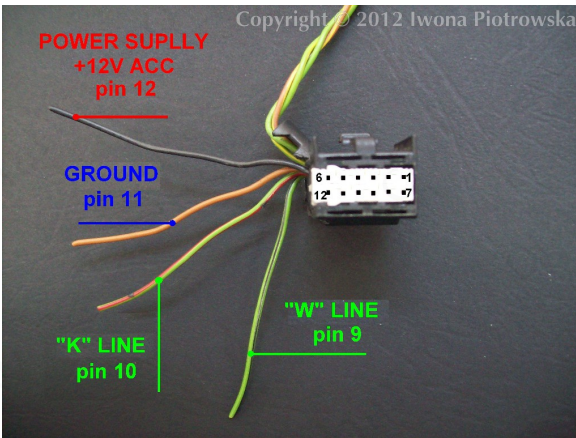

c) 12-pin immobiliser plug

GND	pin 11
+12V ACC	pin 12
K line	pin 10
W line	pin 9

d) 10-pin immobiliser plug
(e.g. certain VW T4 without CAN)

GND	pin 9
+12V ACC	pin 3
K line	pin 8
W line	pin 7

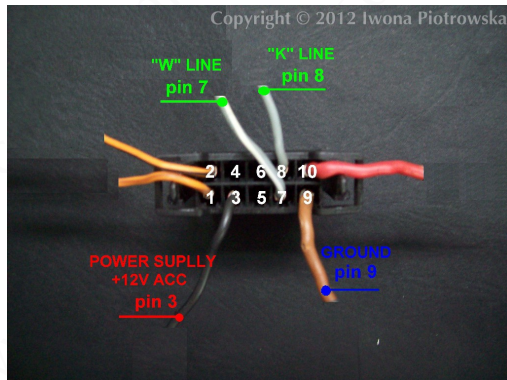

Connect pin 7 and 8 together in the plug of original immobiliser. Then connect emulator to the OBD socket

GND	pin 4
+12V ACC	pin 16
K line	pin 7

e) 12-pin immobilizer plug (e.g. LT35) – 2 - and 5-socket ECUs up to about 2006

GND	pin 2
+12V ACC	pin 7
K line	pin 6
W line	pin 8

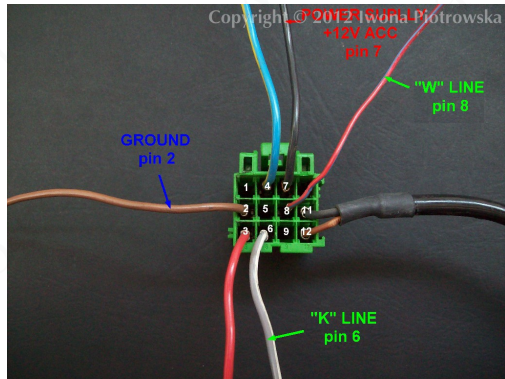

Connecting emulator to ECU



GND	pin 1
+12V ACC	pin 38
K line	pin 43

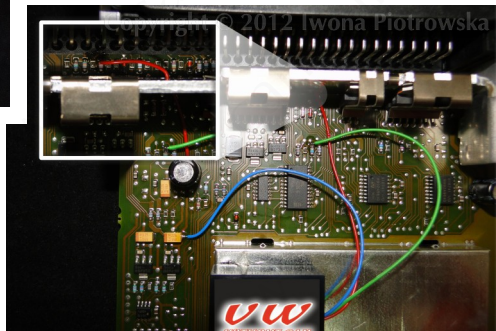

Warning!!!

Due to possible construction changes of cars, check signals with multimeter in the ECU plug.

We state that we are the only authentic authors of this manual. We possess copyright of this publication. All rights reserved. Unauthorized copying, hiring, lending, public performance will be punished!!! Any trials of unauthorized copying, hiring, quoting prohibited!!! Both service and advertisement constitute copyright and they are the subject to the protection in accordance with the Act from 4th Feb. 1994 on Copyright and Related Laws (Statute Book no. 24 position 93) and protection on the basis of the Act from 8th June 1993 on combating an unfair competition (Statute Book no. 47 position 211)

www.carlabimmo.com

Last updated 05.09.2014